



UFEC30 SERIES

CHASSIS-MOUNT DC-DC CONVERTER

2:1 WIDE INPUT RANGE
UP TO 30 Watts



FEATURES

- NO MINIMUM LOAD REQUIRED
- 1600VDC INPUT TO OUTPUT ISOLATION
- APPLICATION OF CHASSIS-MOUNT DC/DC CONVERTERS
- SCREW TERMINALS FOR INPUT AND OUTPUT CONNECTIONS
- INTERNAL INPUT FUSE PROTECTION
- INTERNAL OUTPUT LED INDICATOR
- MEET EN55022 CLASS B
- SAFETY MEETS UL60950-1, EN60950-1, & IEC60950-1
- CE MARKED
- COMPLIANT TO RoHS II & REACH

APPLICATIONS

- WIRELESS NETWORK
- TELECOM/DATACOM
- INDUSTRY CONTROL SYSTEM
- MEASUREMENT EQUIPMENT
- SEMICONDUCTOR EQUIPMENT

1600VDC ISOLATION	REMOTE CONTROL	UVP	OCP	SCP	OVP	FUSE INCLUDED	INRUSH LIMIT	REVERSE POLARITY PROTECTION
-------------------	----------------	-----	-----	-----	-----	---------------	--------------	-----------------------------

TECHNICAL SPECIFICATION

All specifications are typical at nominal input, full load and 25°C otherwise noted

Model Number	Input Range	Output Voltage	Output Current @Full Load	Input Current @ No Load	Efficiency	Maximum Capacitor Load (1)
	VDC	VDC	A	mA	%	µF
UFEC30-12S3P3	9.5 ~ 18	3.3	6	117	83	19500
UFEC30-12S05	9.5 ~ 18	5	6	98	85	10200
UFEC30-12S12	9.5 ~ 18	12	2.5	176	86	3240
UFEC30-12S15	9.5 ~ 18	15	2	218	86	1100
UFEC30-12S24	9.5 ~ 18	24	1.25	72	85	510
UFEC30-12S28	9.5 ~ 18	28	1	54	85	340
UFEC30-12D12	9.5 ~ 18	±12	±1.25	66	85	±1020
UFEC30-12D15	9.5 ~ 18	±15	±1	48	85	±675
UFEC30-24S3P3	18 ~ 36	3.3	6	51	85	19500
UFEC30-24S05	18 ~ 36	5	6	51	87	10200
UFEC30-24S12	18 ~ 36	12	2.5	83	88	3300
UFEC30-24S15	18 ~ 36	15	2	94	88	1100
UFEC30-24S24	18 ~ 36	24	1.25	37	87	510
UFEC30-24S28	18 ~ 36	28	1	38	87	340
UFEC30-24D12	18 ~ 36	±12	±1.25	33	87	±1020
UFEC30-24D15	18 ~ 36	±15	±1	34	87	±675
UFEC30-48S3P3	36 ~ 75	3.3	6	31	86	19500
UFEC30-48S05	36 ~ 75	5	6	36	88	10200
UFEC30-48S12	36 ~ 75	12	2.5	37	89	3300
UFEC30-48S15	36 ~ 75	15	2	57	89	1100
UFEC30-48S24	36 ~ 75	24	1.25	28	87	510
UFEC30-48S28	36 ~ 75	28	1	28	87	340
UFEC30-48D12	36 ~ 75	±12	±1.25	22	87	±1020
UFEC30-48D15	36 ~ 75	±15	±1	22	87	±675

PART NUMBER STRUCTURE

UFEC30 -	48	S	05	-	EC
Series Name	Input Voltage (VDC)	Output Quantity	Output Voltage (VDC)		Assembly Option
	12: 9.5~18 24: 18-36 48: 36~75	S: Single	3P3: 3.3 05: 5 12: 12 15: 15 24: 24 28: 28		□: None EC: Enclosed Mounting Type DR: Din Rail Mounting Type ED: Enclosed & Din Rail Mounting Type
		D: Dual	12: ±12 15: ±15		

INPUT SPECIFICATIONS

Parameter	Conditions		Min.	Typ.	Max.	Unit
Operating input voltage range		12Vin(nom)	9.5	12	18	VDC
		24Vin(nom)	18	24	36	
		48Vin(nom)	36	48	75	
Input fuse (slow blow)		12Vin(nom)		6		A
		24Vin(nom)		6		
		48Vin(nom)		4		
In-rush current				15		A
Input reflected ripple current	Nominal input and Full load			15		mAp-p
Start up voltage		12Vin(nom)			9.5	VDC
		24Vin(nom)			18	
		48Vin(nom)			36	
Shutdown voltage		12Vin(nom)		8		VDC
		24Vin(nom)		16		
		48Vin(nom)		33		
Start up time	Constant resistive load	Power up		100		ms
		Remote ON/OFF		25		
Input surge voltage	100ms, max.	12Vin(nom)			36	VDC
		24Vin(nom)			50	
		48Vin(nom)			100	
Remote ON/OFF	Referred to -Vin pin	Positive logic DC-DC ON	Open or 3 ~ 12VDC			mA
		DC-DC OFF	Short or 0 ~ 1.2VDC			
		Input current of Ctrl pin	-0.5		0.5	mA
		Remote off input current		2.5		mA

OUTPUT SPECIFICATIONS

Parameter	Conditions		Min.	Typ.	Max.	Unit
Voltage accuracy		3.3Vout	-1.5		+1.5	%
		Others	-1.0		+1.0	
Line regulation	Low Line to High Line at Full Load	Single	-0.2		+0.2	%
		Dual	-0.5		+0.5	
Load regulation	No Load to Full Load	3.3Vout	-1.5		+1.5	%
		Others	-1.0		+1.0	
Cross regulation	Asymmetrical load 25%/100% FL	Dual	-5.0		+5.0	%
Voltage adjustability	Single output	28Vout	-3		+17	%
		Others	-10		+10	
Ripple and noise	Measured by 20MHz bandwidth	Single	3.3Vout, 5Vout	50		mVp-p
			12Vout, 15Vout	75		
		Dual	24Vout, 28Vout	100		
		All	100			
Temperature coefficient			-0.02		+0.02	%/°C
Transient response recovery time	25% load step change			300		µs
Over voltage protection	Zener diode clamp	3.3Vout		3.9		VDC
		5Vout		6.2		
		12Vout		15		
		15Vout		18		
		24Vout		30		
		28Vout		36		
Output indicator				Green LED		
Over load protection	% of Iout rated			150		%
Short circuit protection				Continuous, automatic recovery		

GENERAL SPECIFICATIONS

Parameter	Conditions		Min.	Typ.	Max.	Unit
Isolation voltage	1 minute	Input to Output	1600			VDC
		Input (Output) to Chassis	1600			
Isolation resistance	500VDC		1			GΩ
Isolation capacitance					4000	pF
Switching frequency			270	300	330	kHz
Safety meets						UL60950-1 EN60950-1 IEC60950-1
Chassis material						Aluminum
Weight						110g (3.87oz)
MTBF	MIL-HDBK-217F, Full load					1.259 x 10 ⁶ hrs

ENVIRONMENTAL SPECIFICATIONS

Parameter	Conditions	Min.	Typ.	Max.	Unit
Operating ambient temperature	Without derating	-40		+61	°C
	With derating	+61		+88	
Over temperature protection	DC/DC Converter Case		110		°C
Storage temperature range		-40		+105	°C
Thermal shock					MIL-STD-810F
Vibration					MIL-STD-810F
Relative humidity					5% to 95% RH

EMC SPECIFICATIONS

Parameter	Conditions	Level
EMI	EN55022	Class B
ESD	EN61000-4-2	Perf. Criteria A
Radiated immunity	Air ± 8kV and Contact ± 6kV	Perf. Criteria A
Fast transient	10V/m	Perf. Criteria A
Surge	± 2kV	Perf. Criteria A
Conducted immunity	± 1kV	Perf. Criteria A
Power frequency magnetic field	10Vr.m.s	Perf. Criteria A
	100A/m continuous; 1000A/m 1 second	Perf. Criteria A

Note:

1. Test by minimum input and constant resistive load.

CHARACTERISTIC CURVE

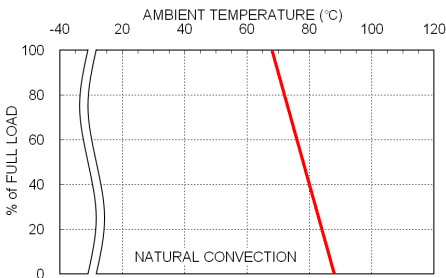

UFEC30-48S05 Derating Curve

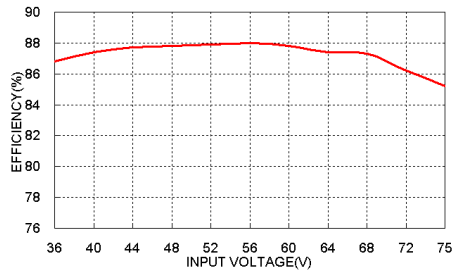

UFEC30-48S05 Efficiency vs. Input Voltage

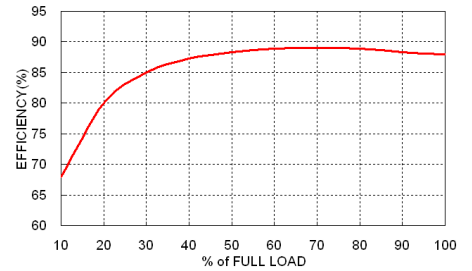

UFEC30-48S05 Efficiency vs. Output Load

MECHANICAL DRAWING

CHASSIS MOUNTING TYPE

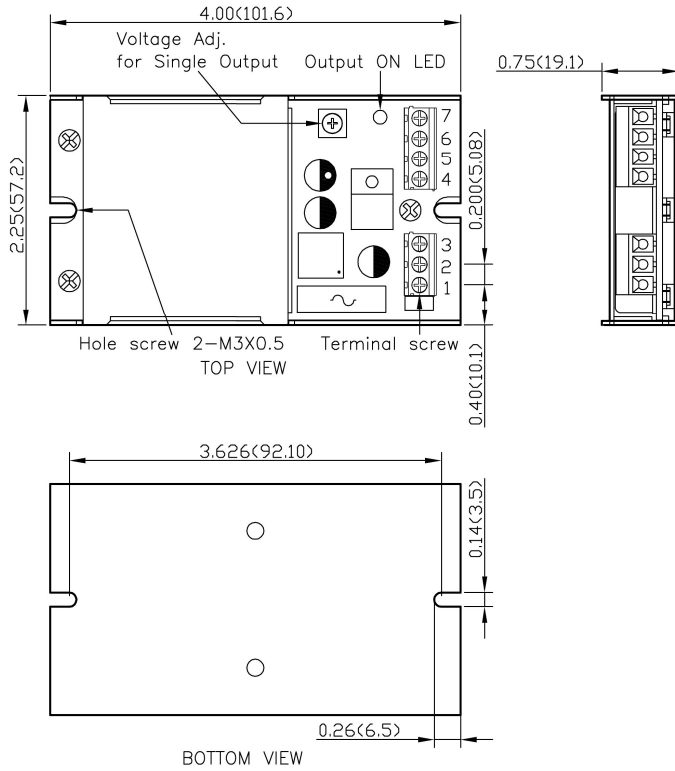

PIN CONNECTION

PIN	SINGLE	DUAL
1	+Vin	+Vin
2	-Vin	-Vin
3	Ctrl	Ctrl
4	NC	NC
5	-Vout	-Vout
6	+Vout	Common
7	NC	+Vout

* NC : No Connection
 * Screw terminals – wire range from 14 to 18 AWG

ENCLOSED MOUNTING TYPE

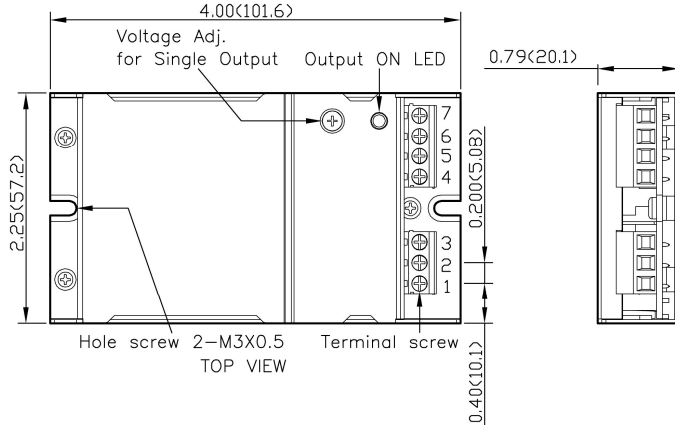

DIN RAIL MOUNTING TYPE

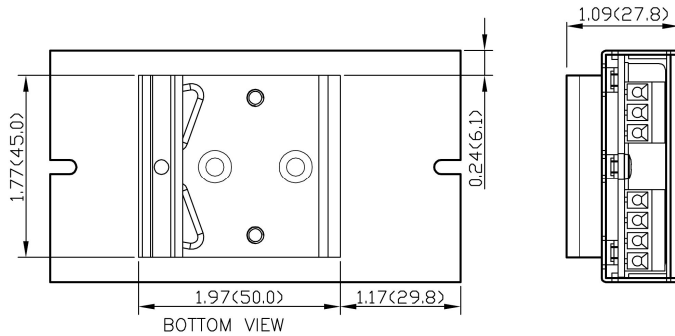

1. All dimensions in Inch (mm)
2. Tolerance : X.XX±0.02 (X.X±0.5)
X.XXX±0.01 (X.XX±0.25)
3. Hole screw locked torque :
MAX 5.0kgf – cm (0.49N – m)
4. Terminal screw locked torque :
MAX 2.5kgf – cm (0.25N – m)